

Boiler Appliances

Bob Sorenson

Objectives

- a. Safety Valves
- b. Water Gauges
- c. Pressure Gauges
- d. Plug Valve
- e. Throttles
- f. Check Valves
- g. Feedwater Parts
- h. Other Stuff

Safety Valves

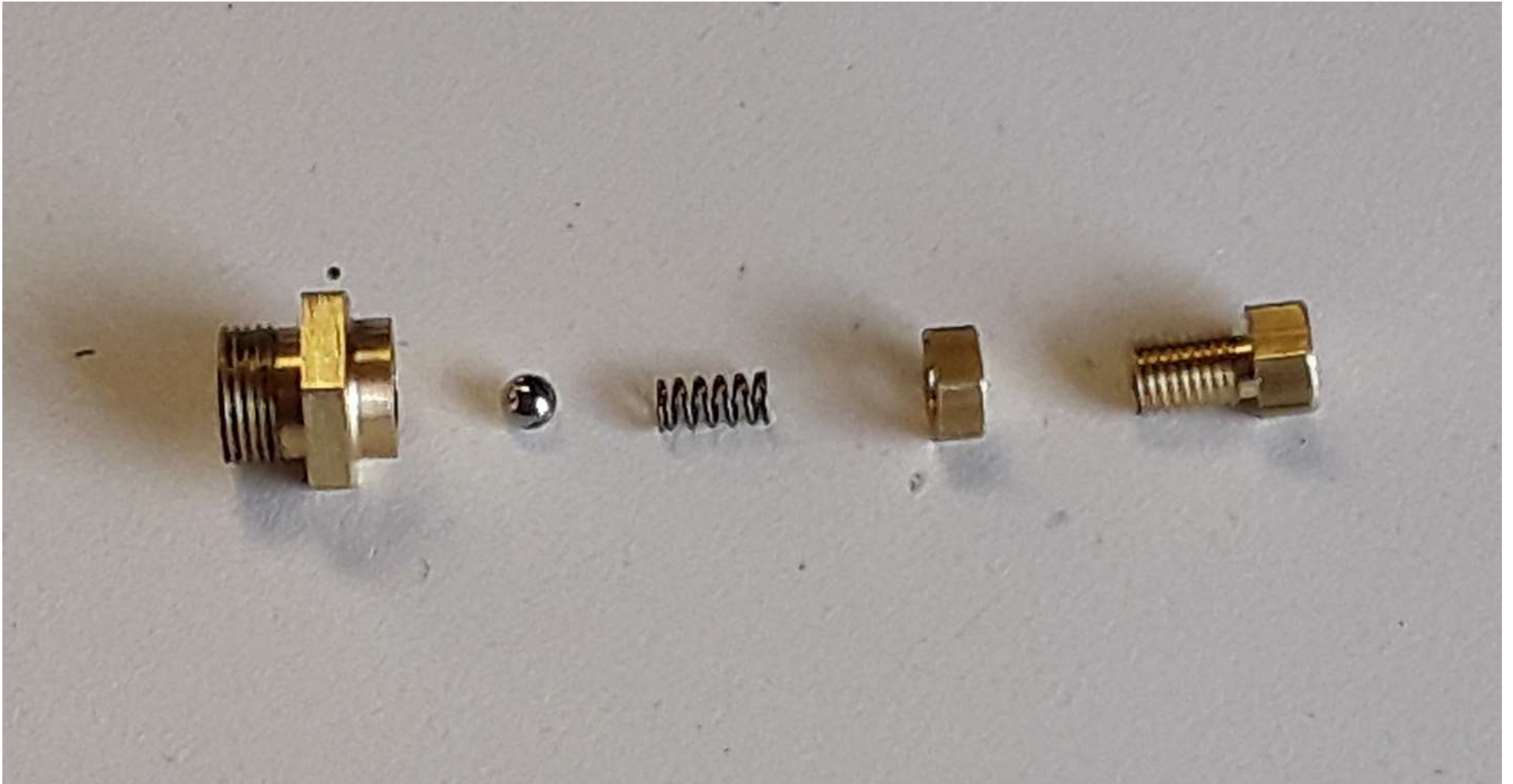

Safety Valves

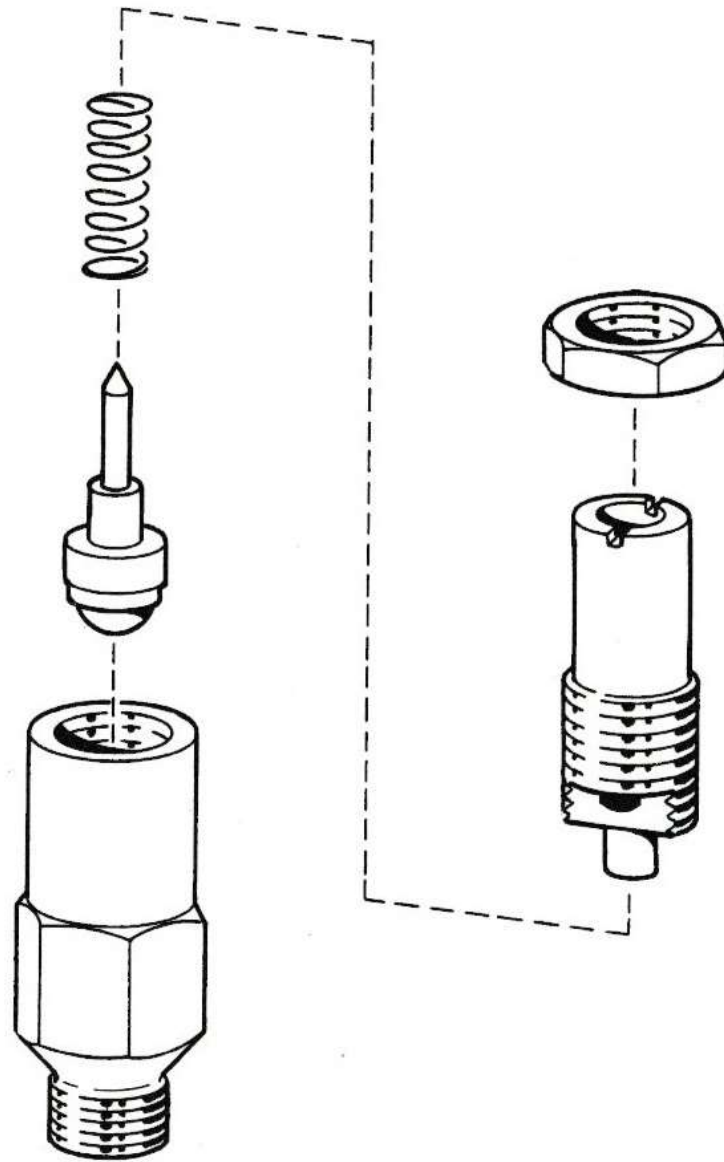

Safety Valves

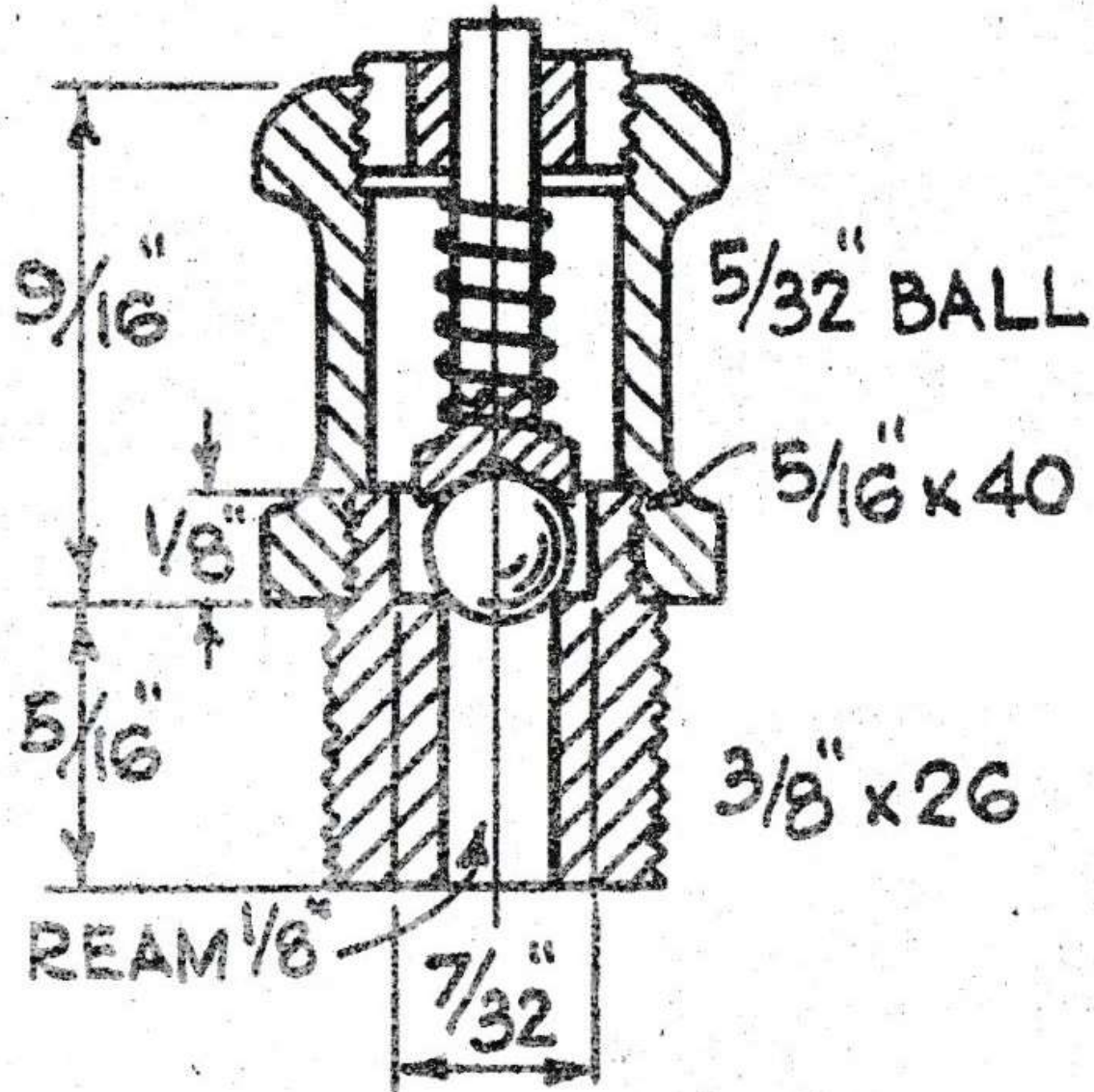

Safety Valves

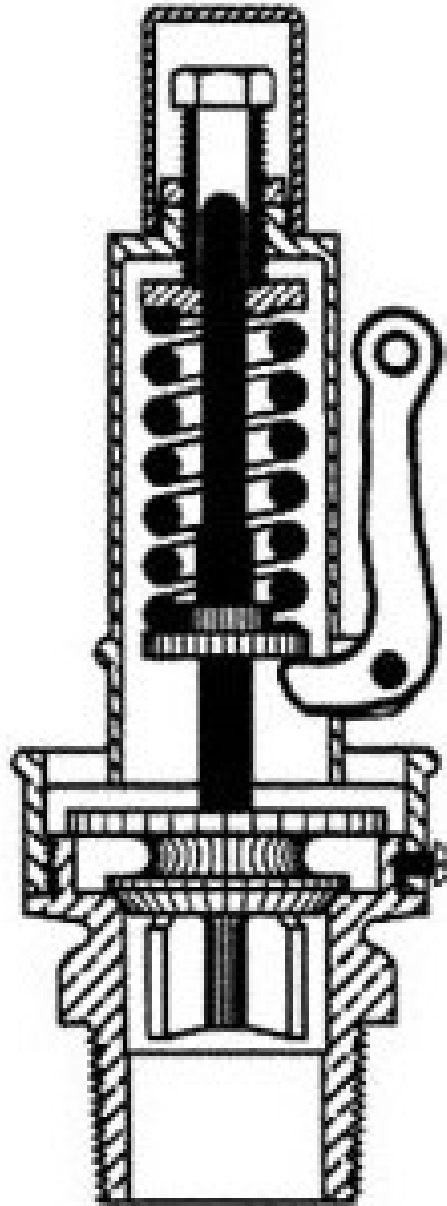

Safety Valves

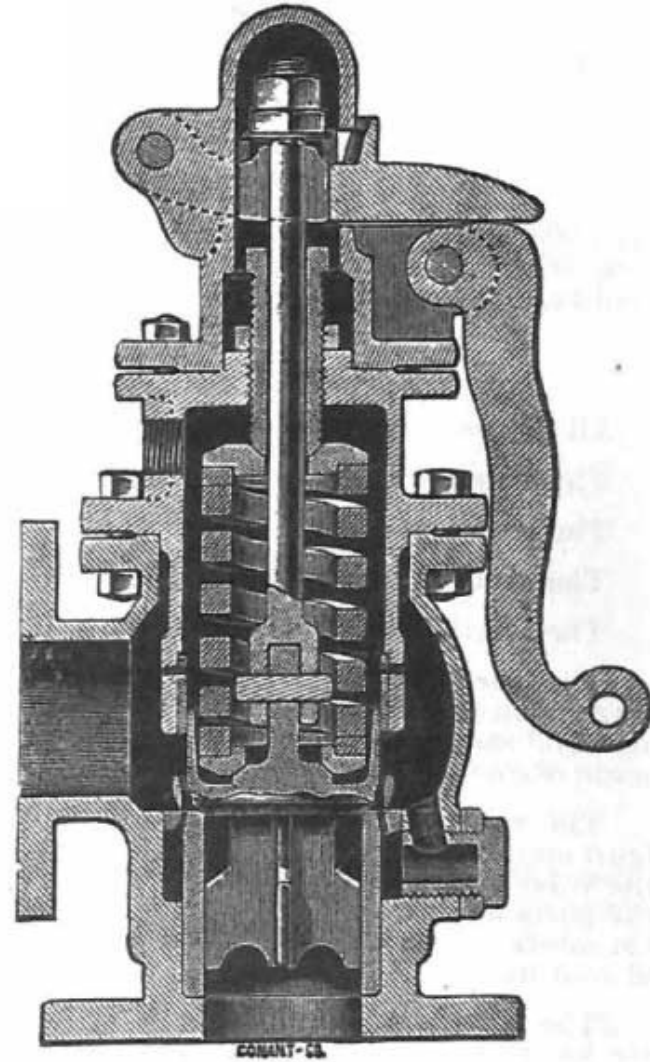
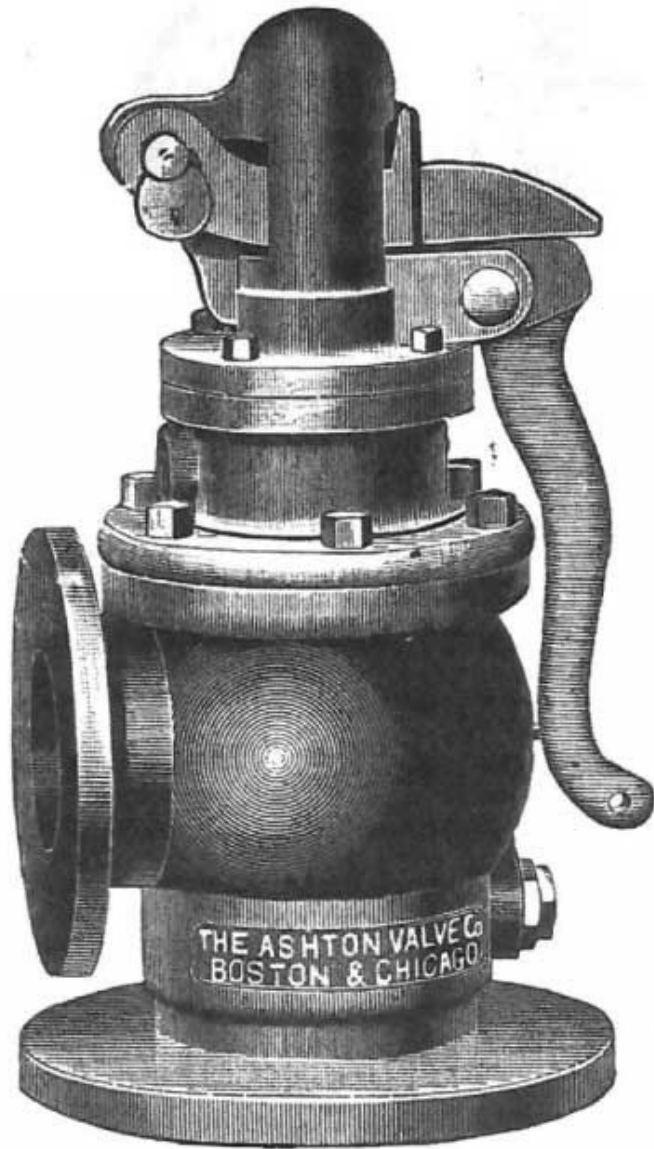

Safety Valves

Dead Weight

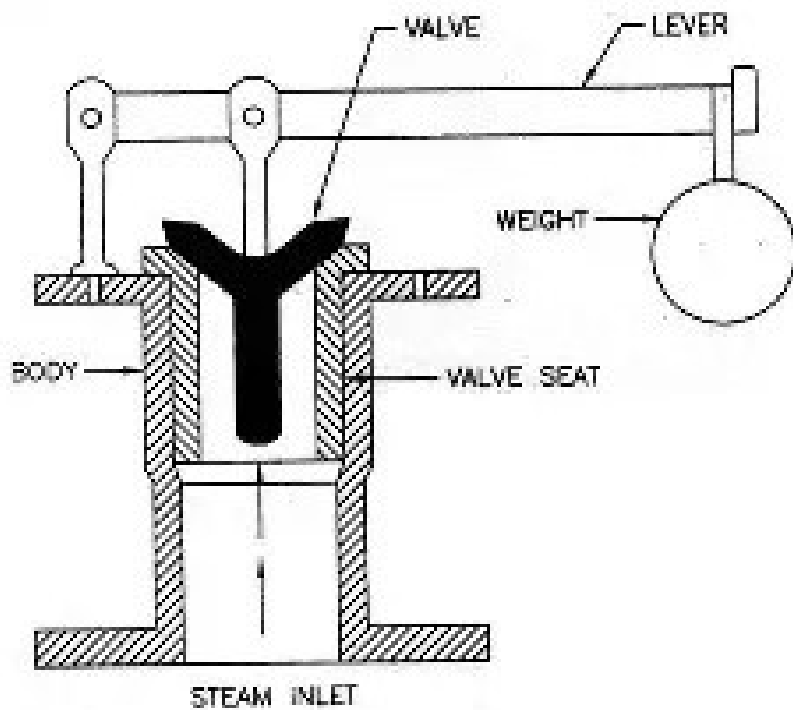

Water Gauges



Water Gauges



Water Gauges

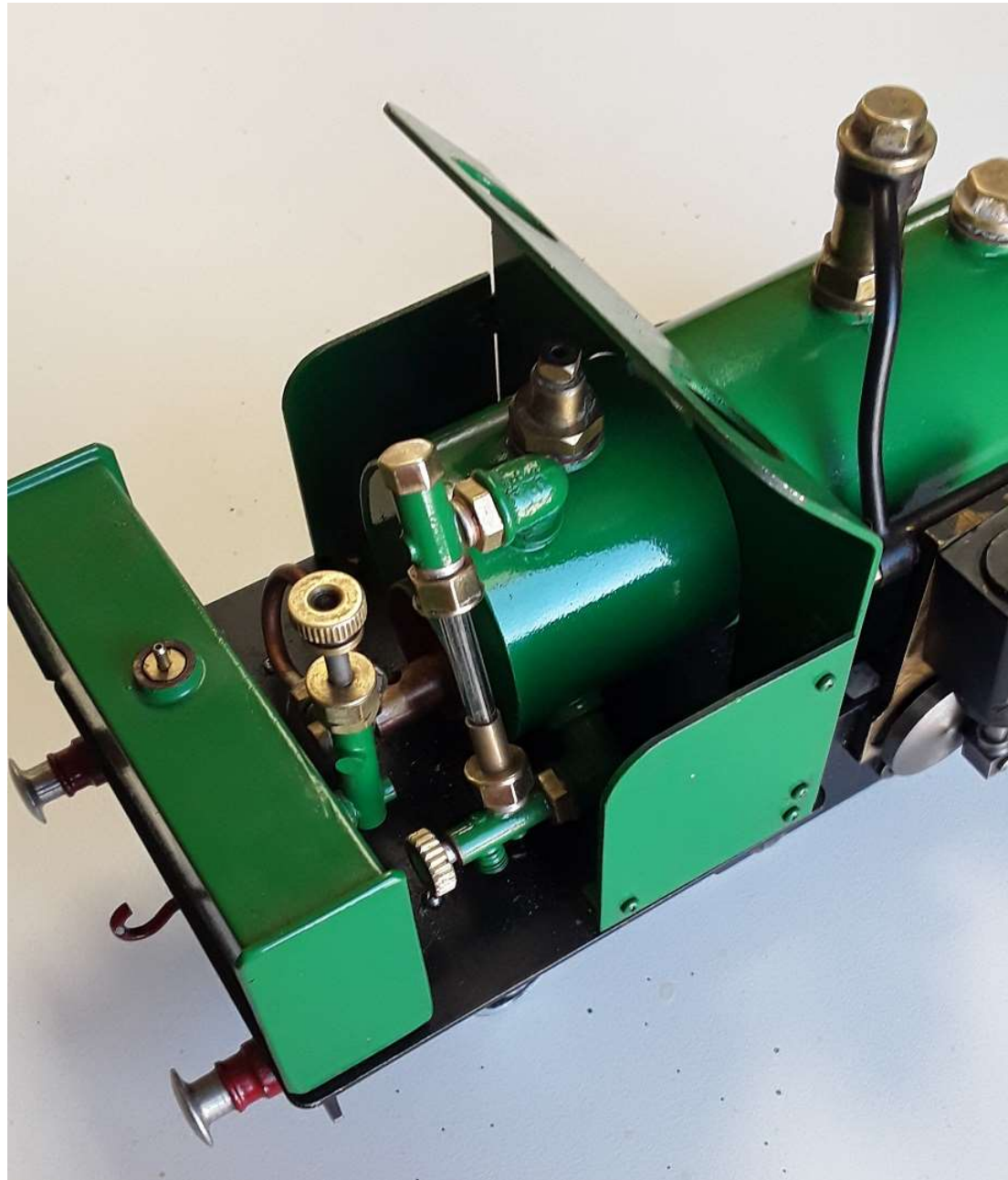

Water Gauges

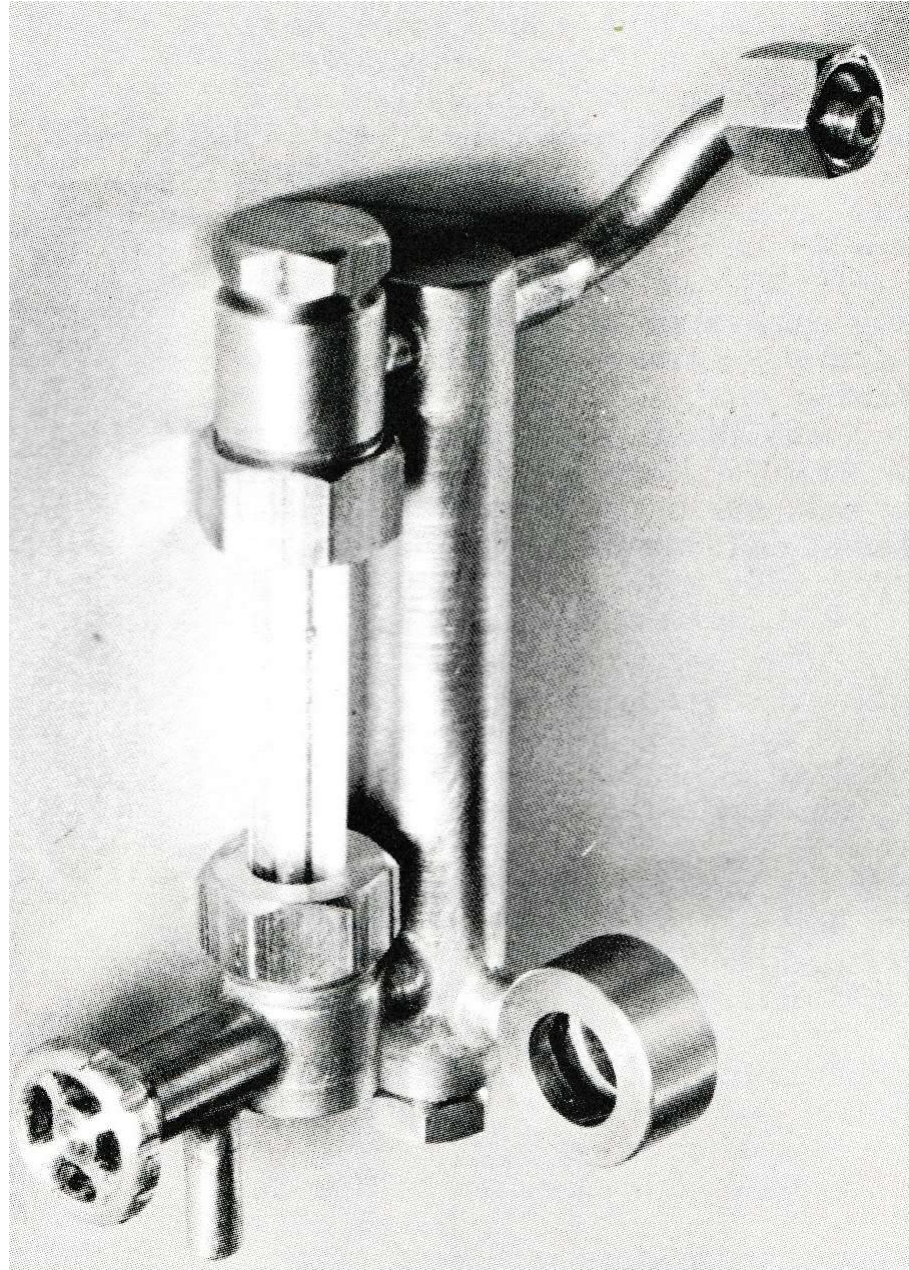

Water Gauges



Water Gauges



Pressure Gauges



Pressure Gauges

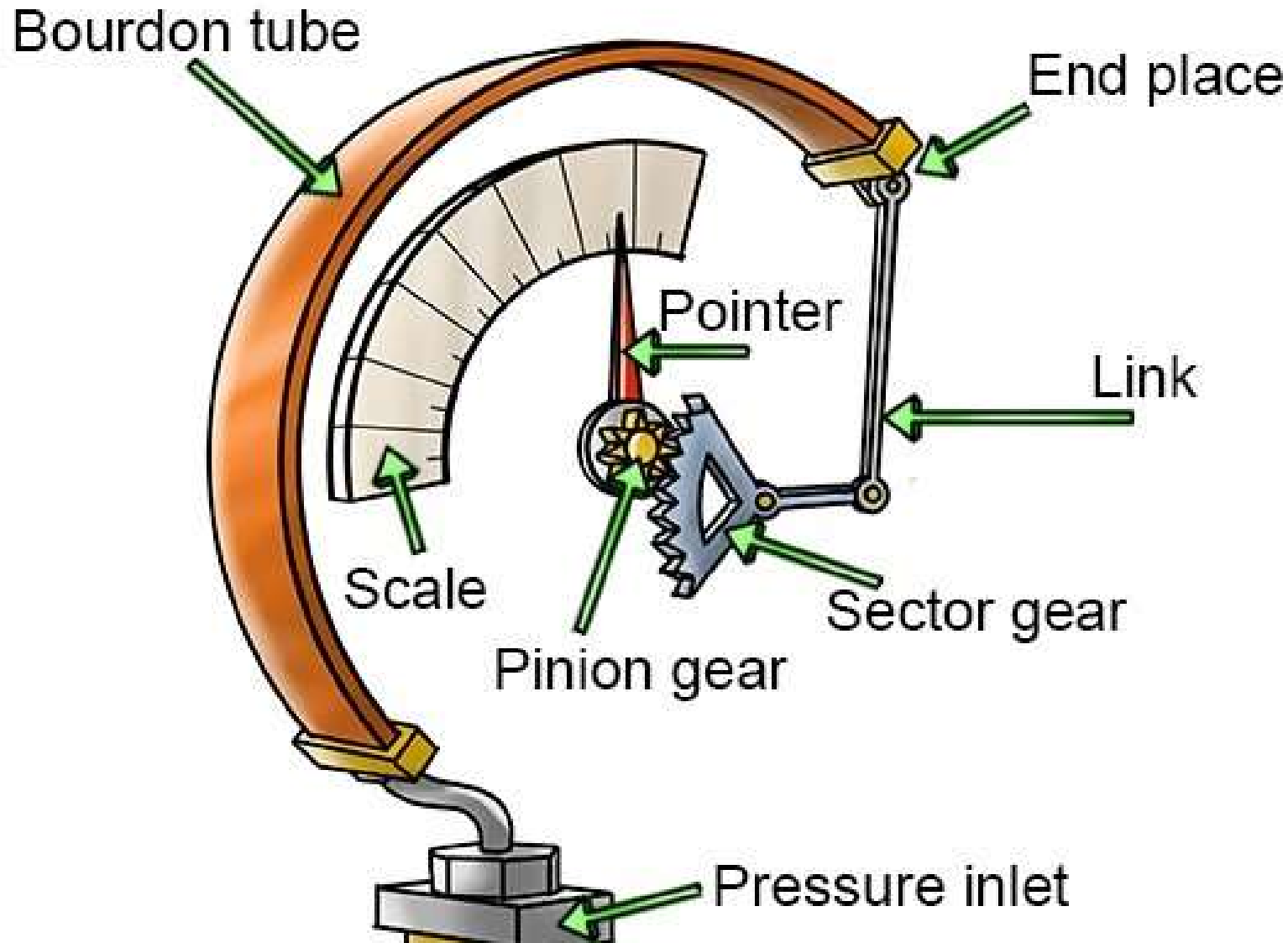

Pressure Gauges



Pressure Gauges



Plug Valves



Plug Valves

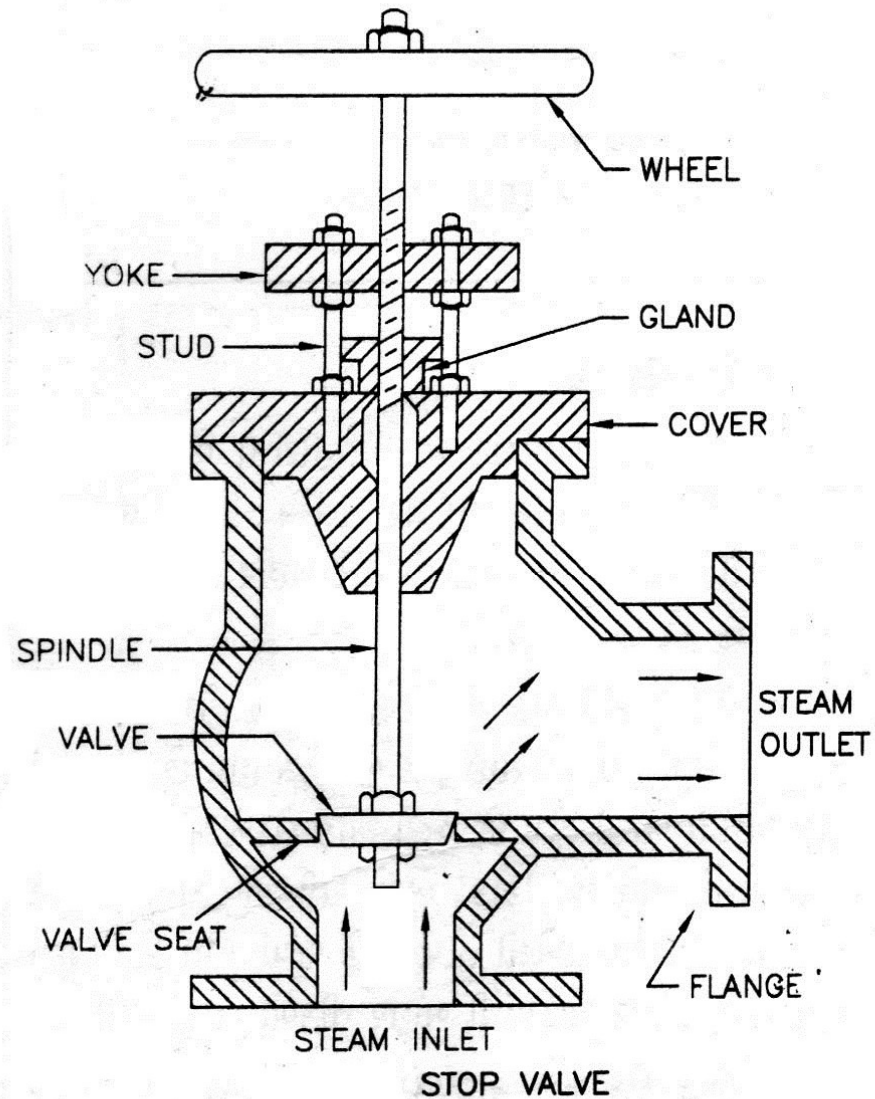

Plug Valves

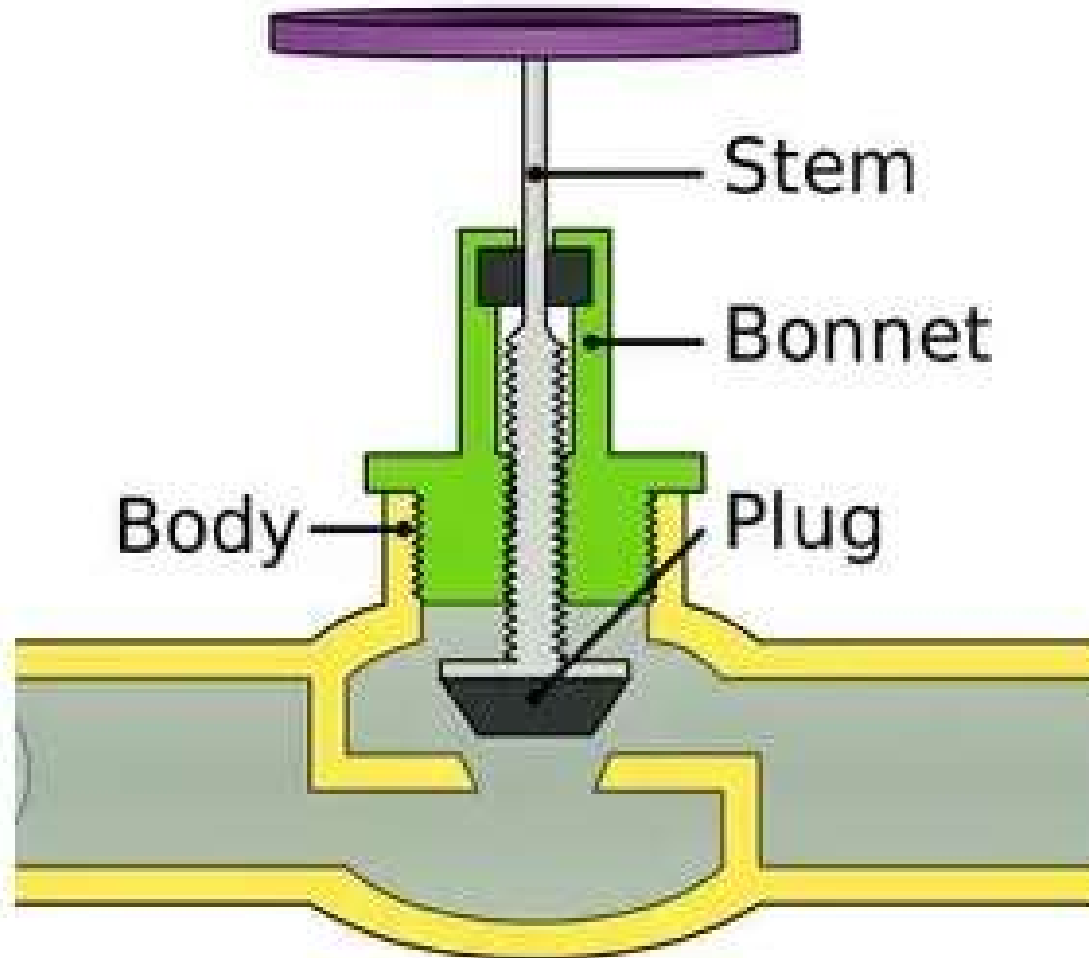

Plug Valves



Throttles



Throttles

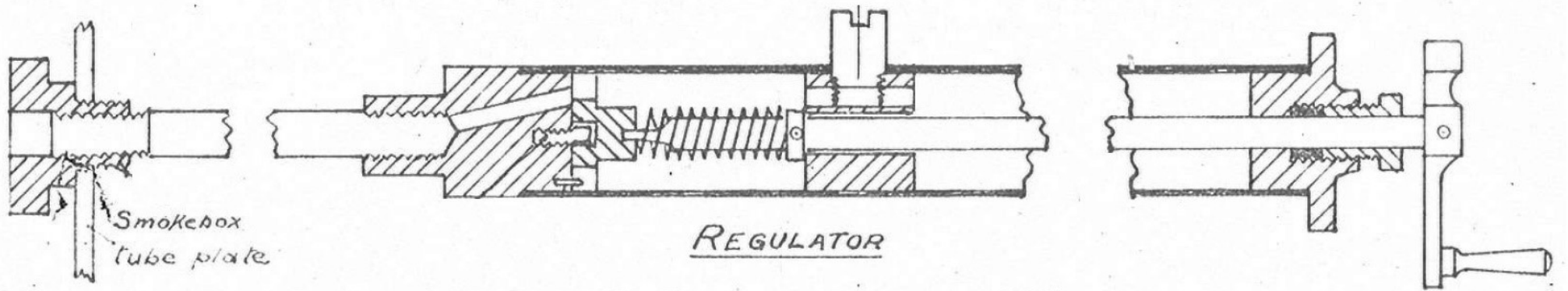

Throttles

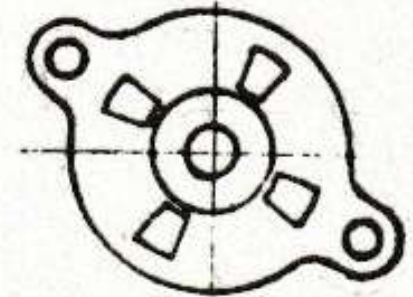
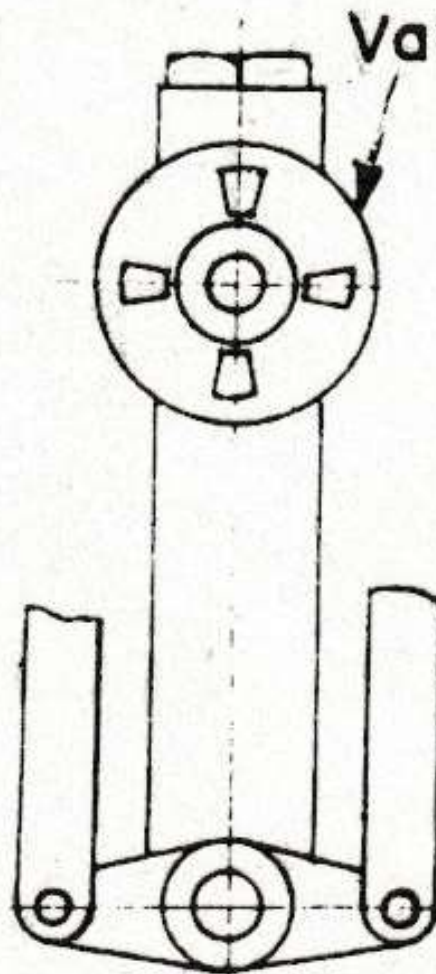
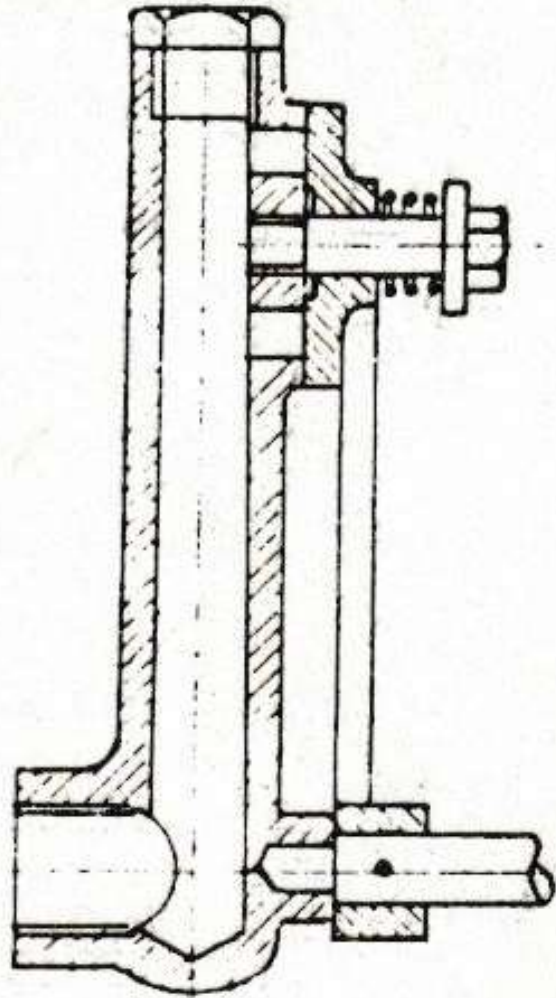

Valve in closed position

Throttles

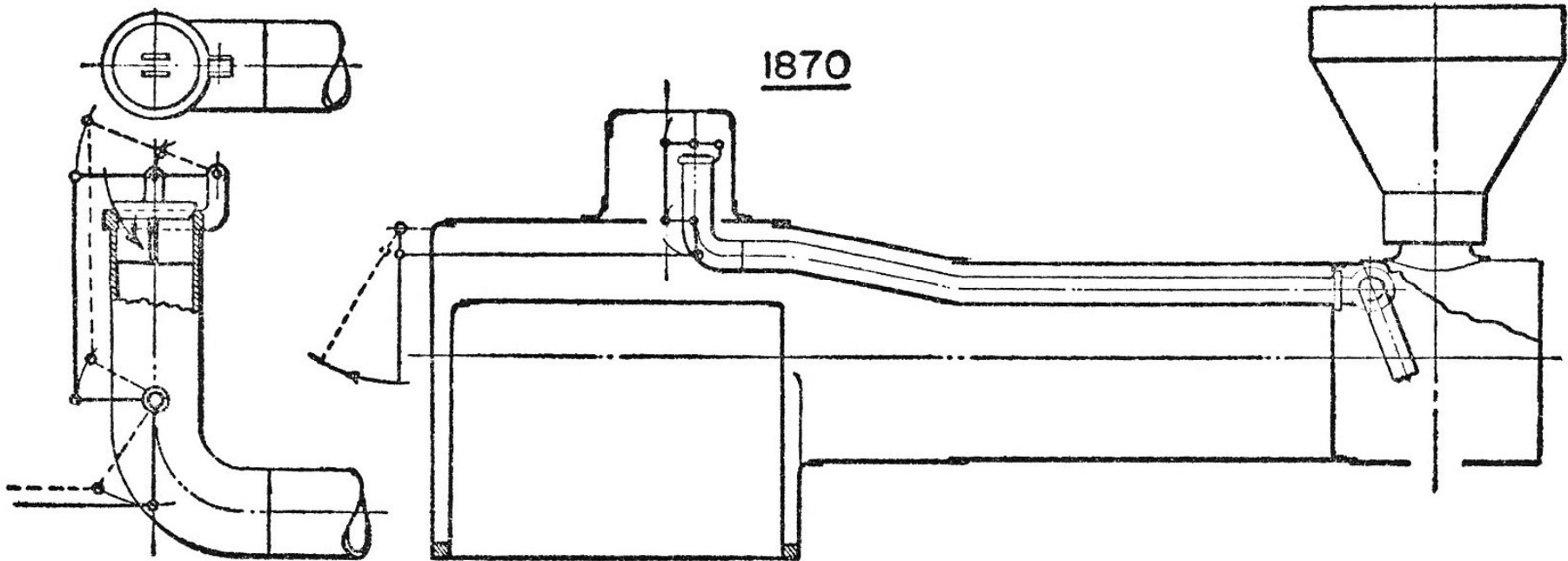

Throttles

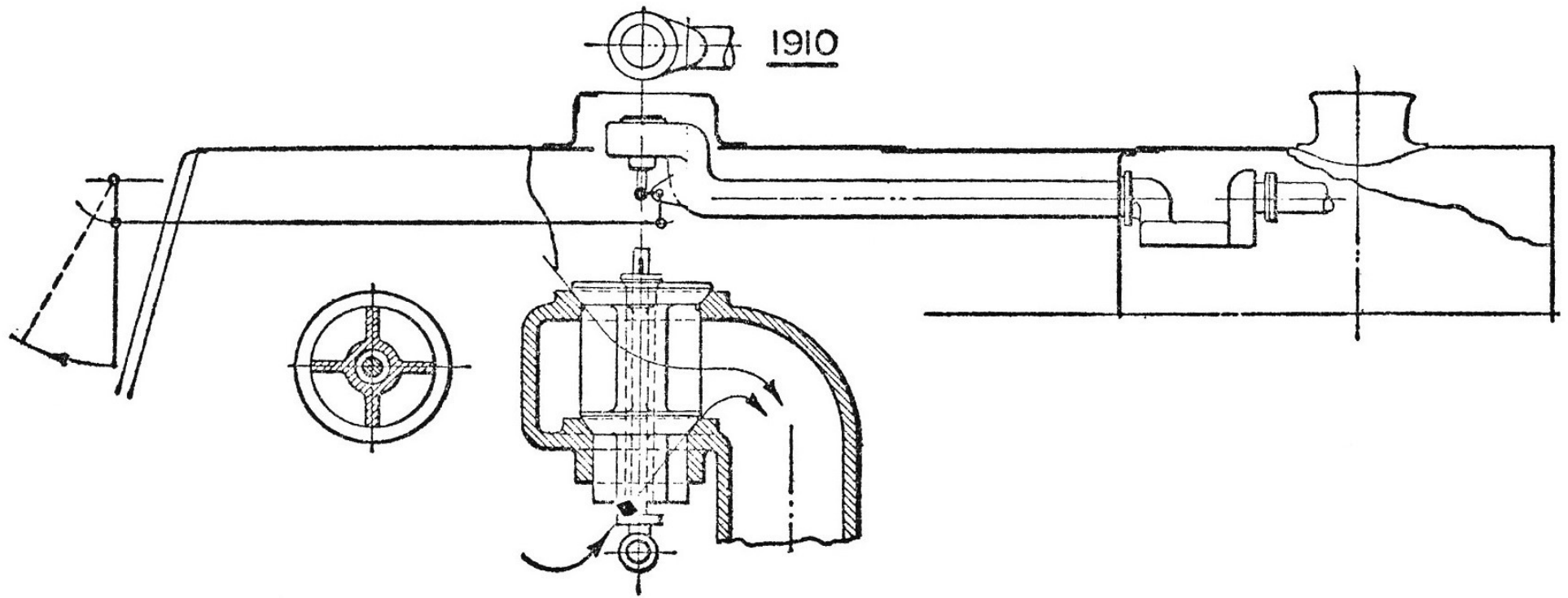

Check Valves

Water
Out



Water
In

Water
Out



Water
In

Check Valves

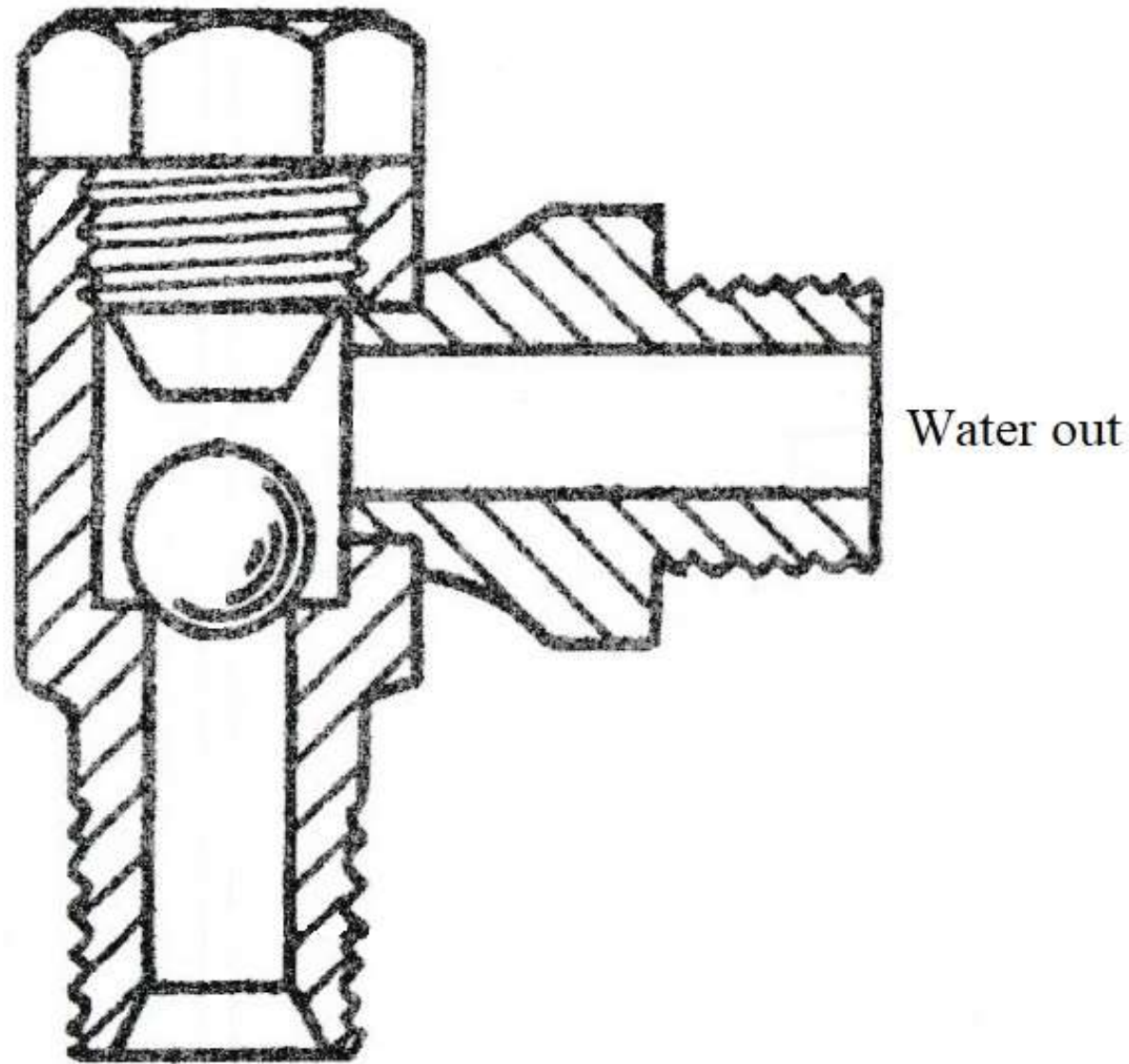

Water in

Water out

Check Valves

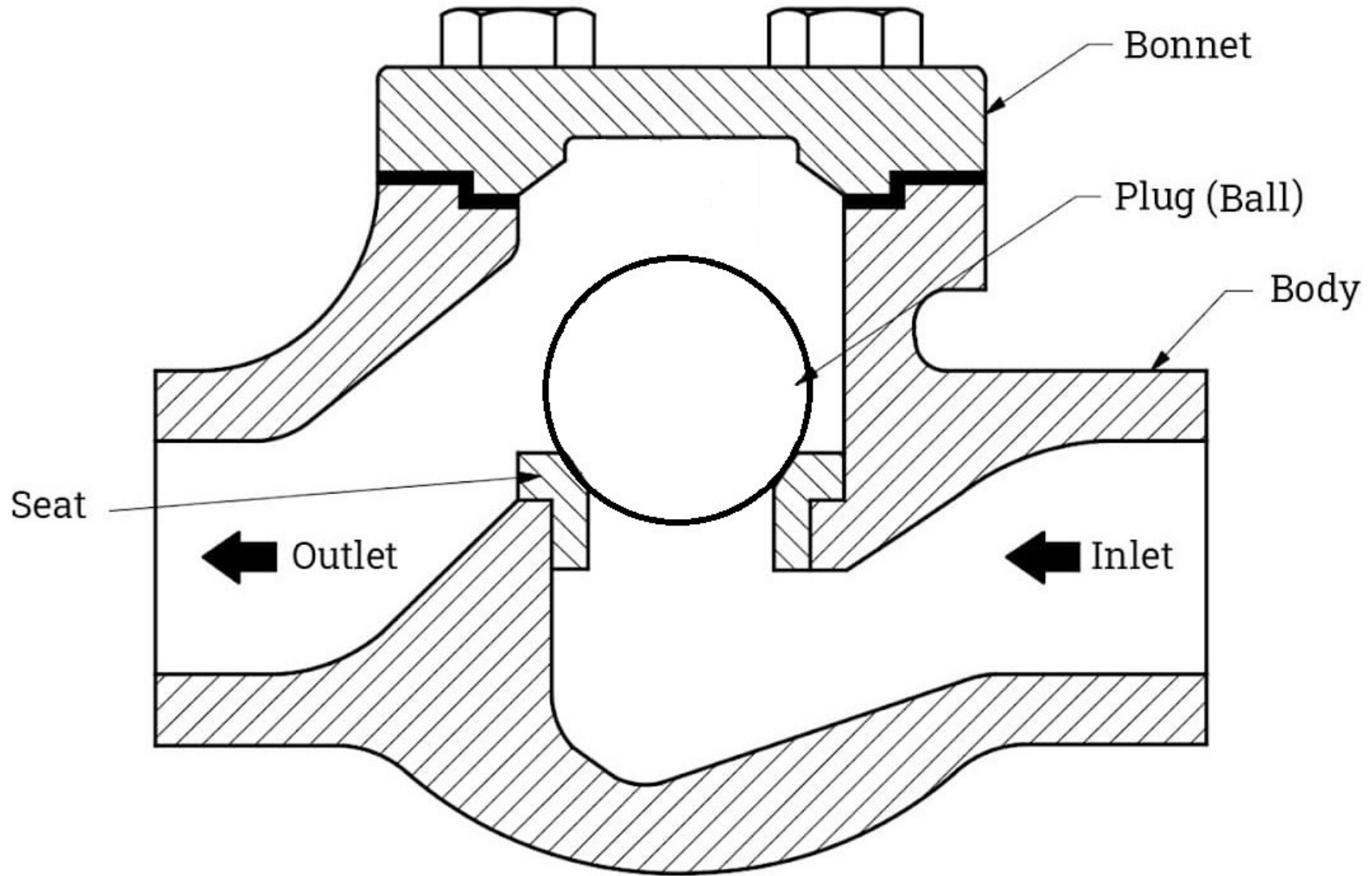

Check Valves

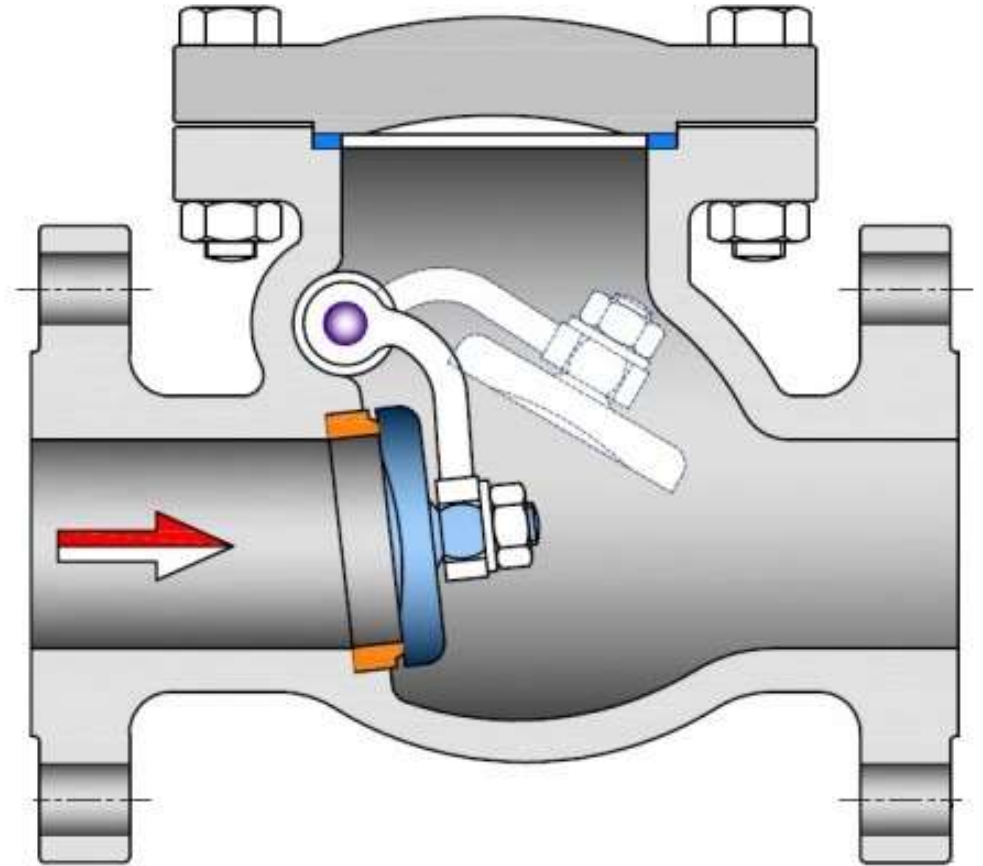
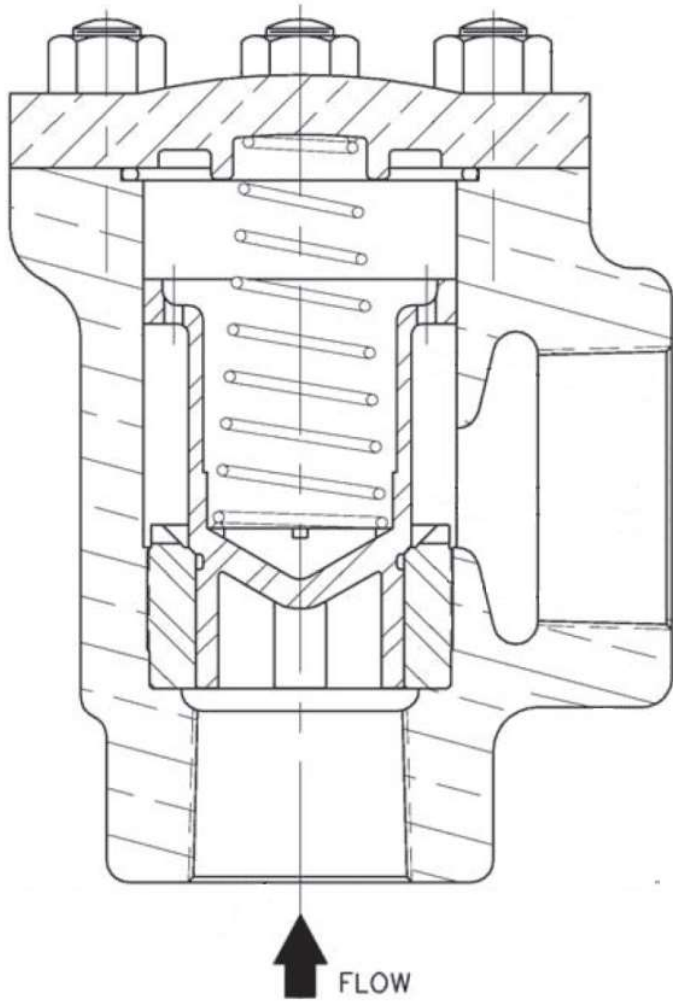

Feedwater



Feedwater

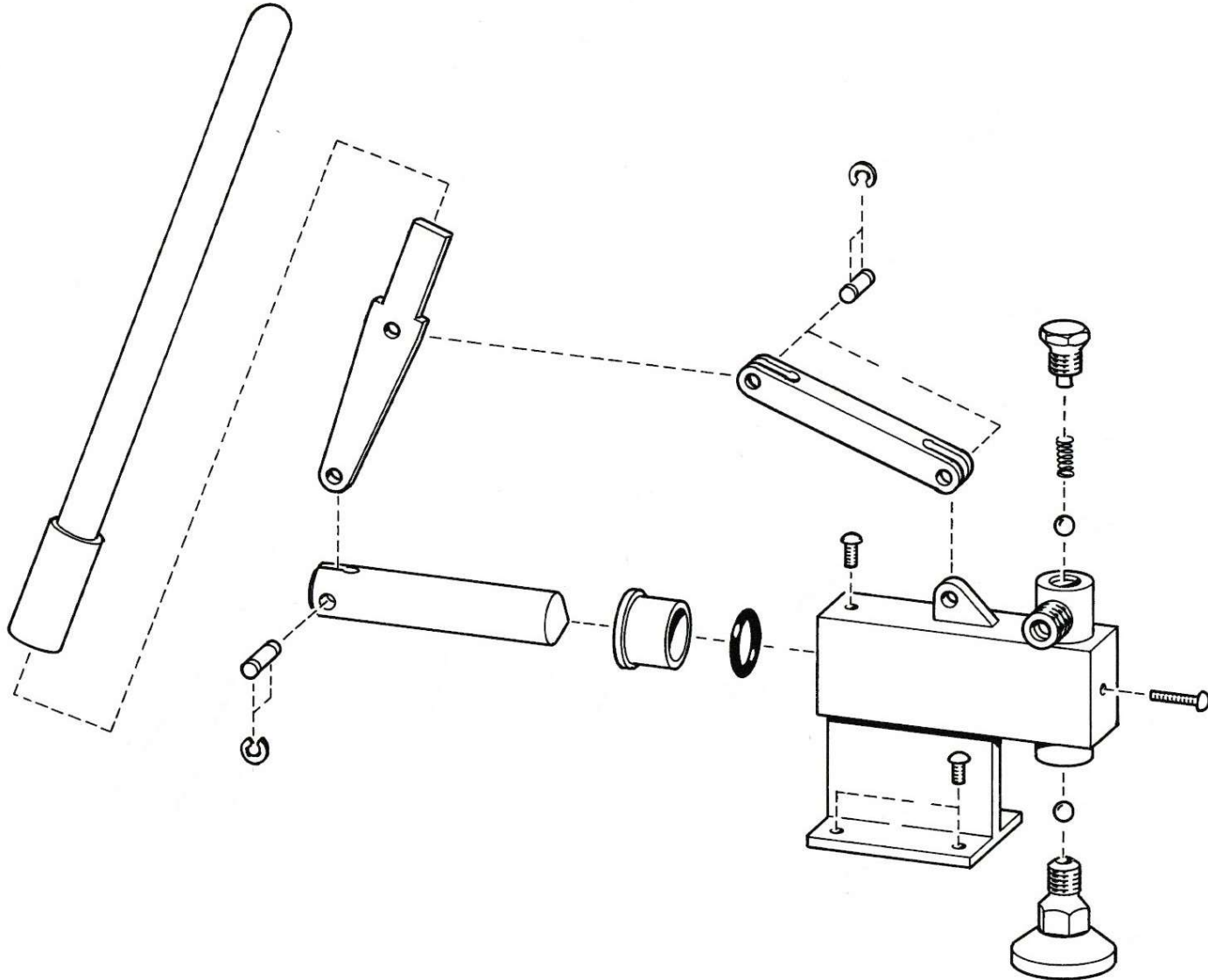

Feedwater

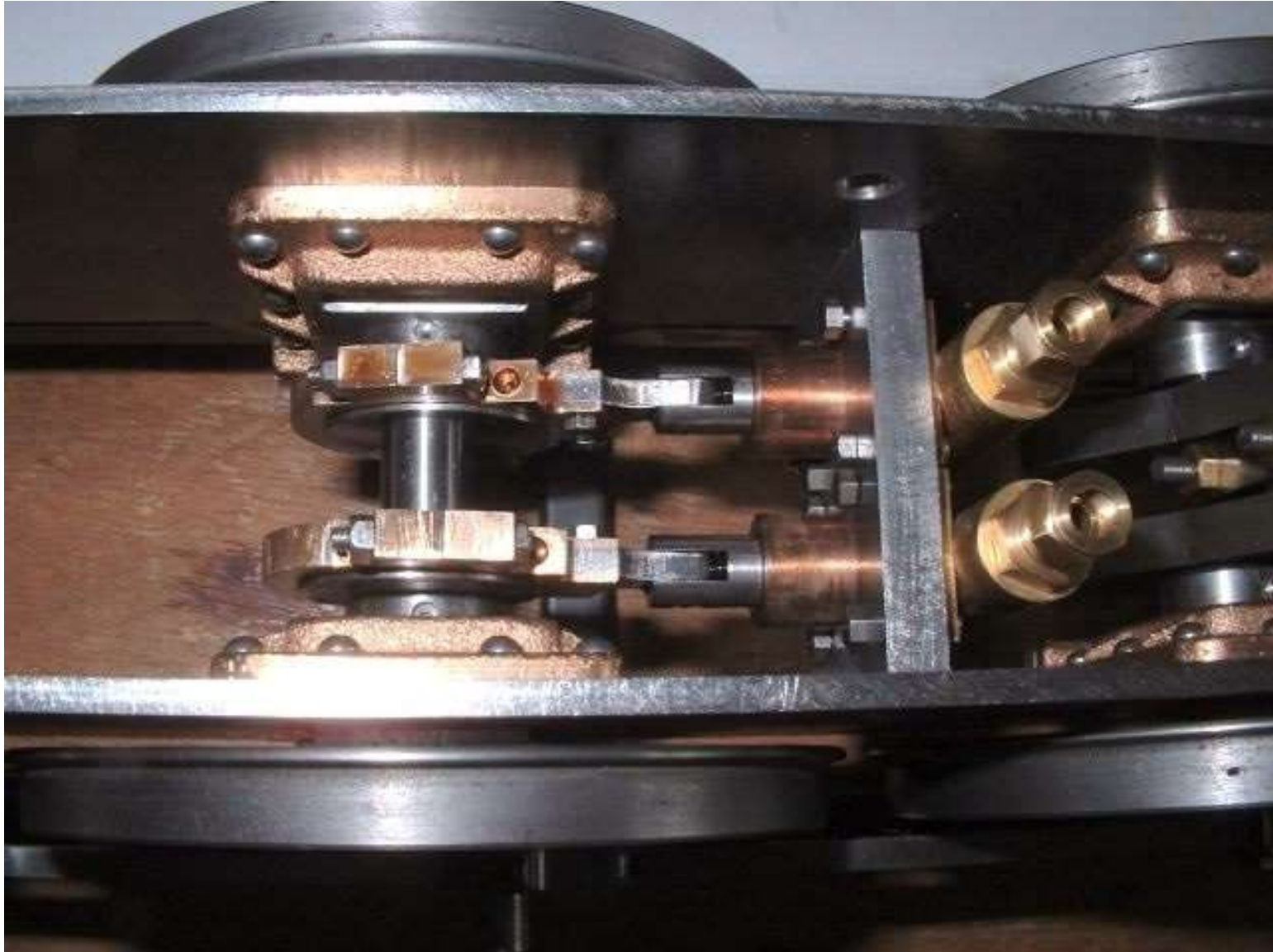

Feedwater

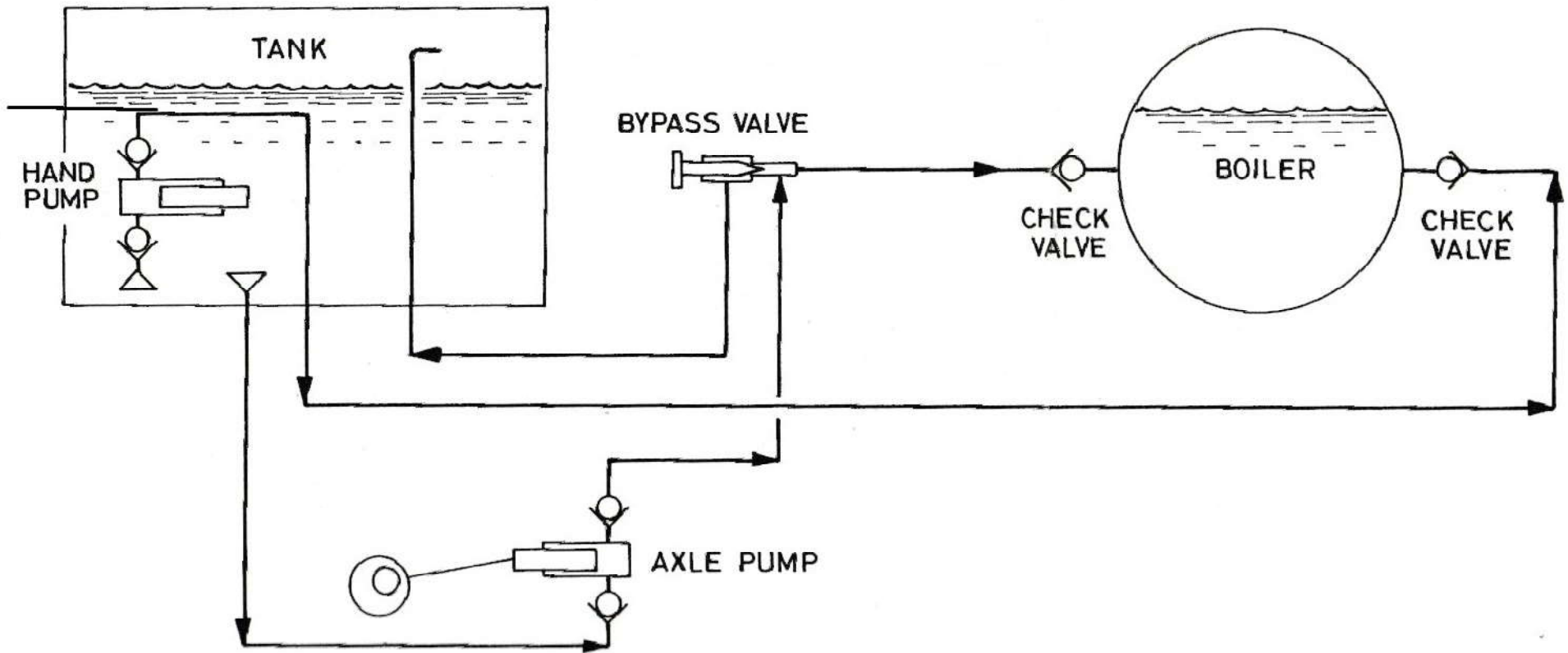

Feedwater

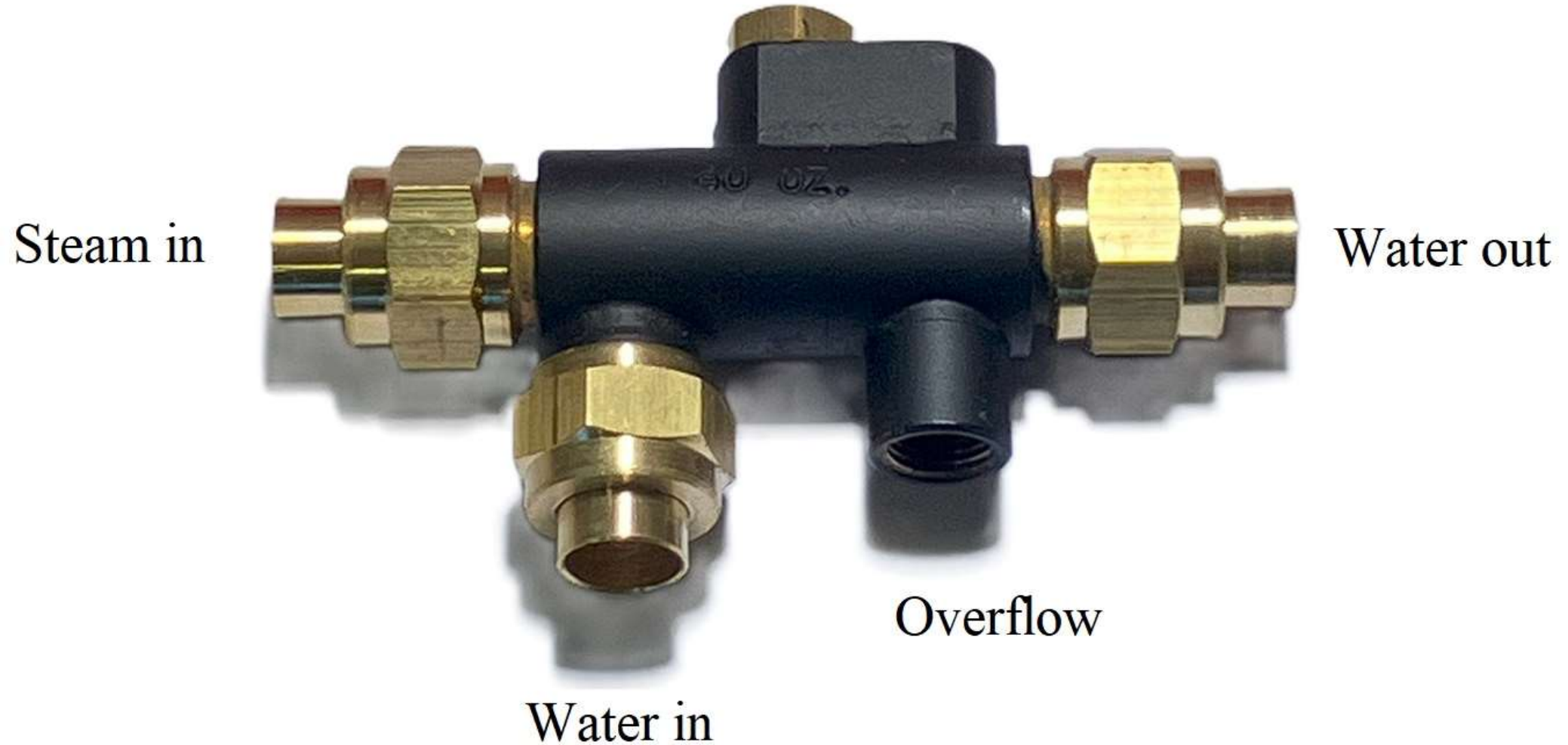

Feedwater

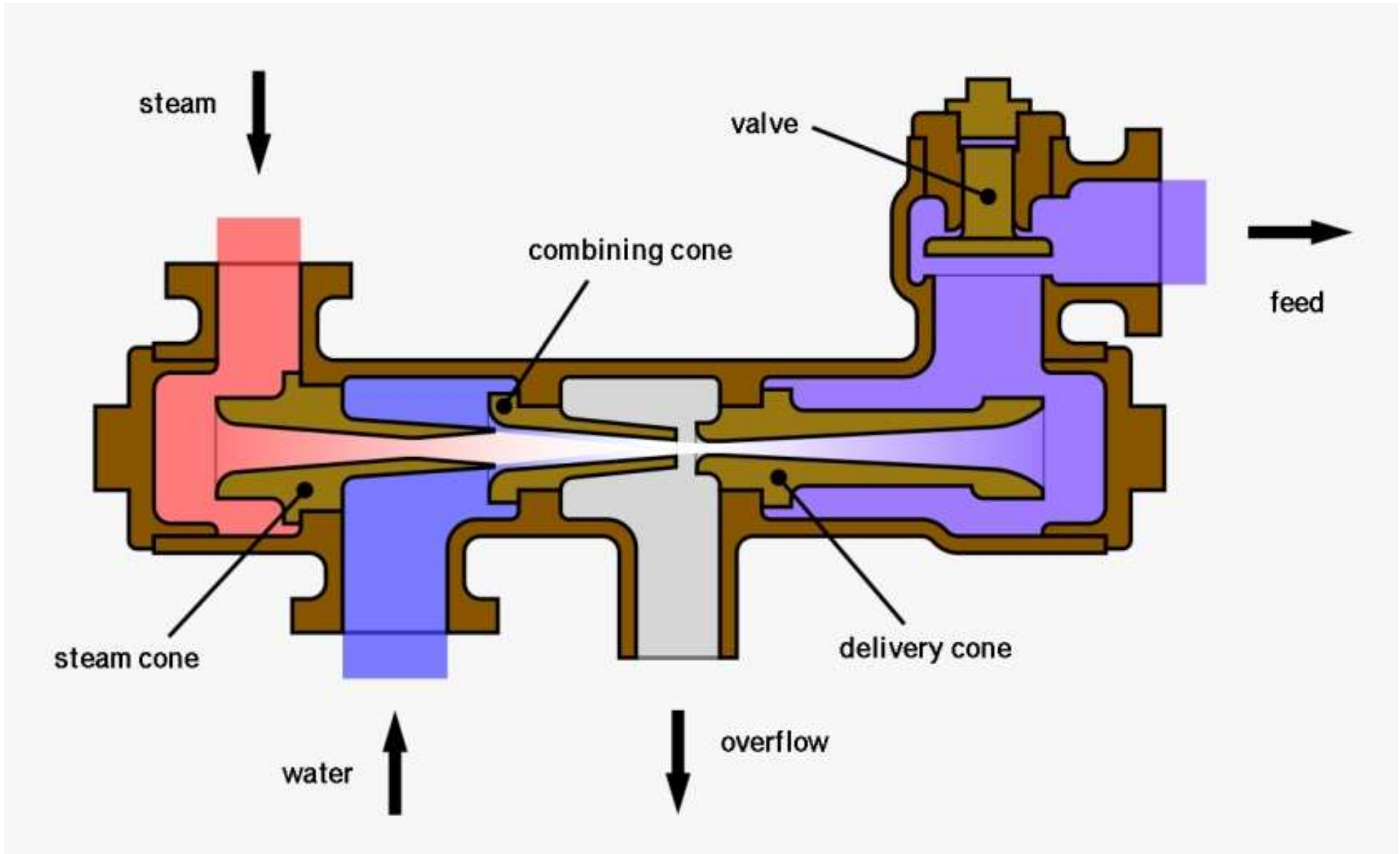

Feedwater

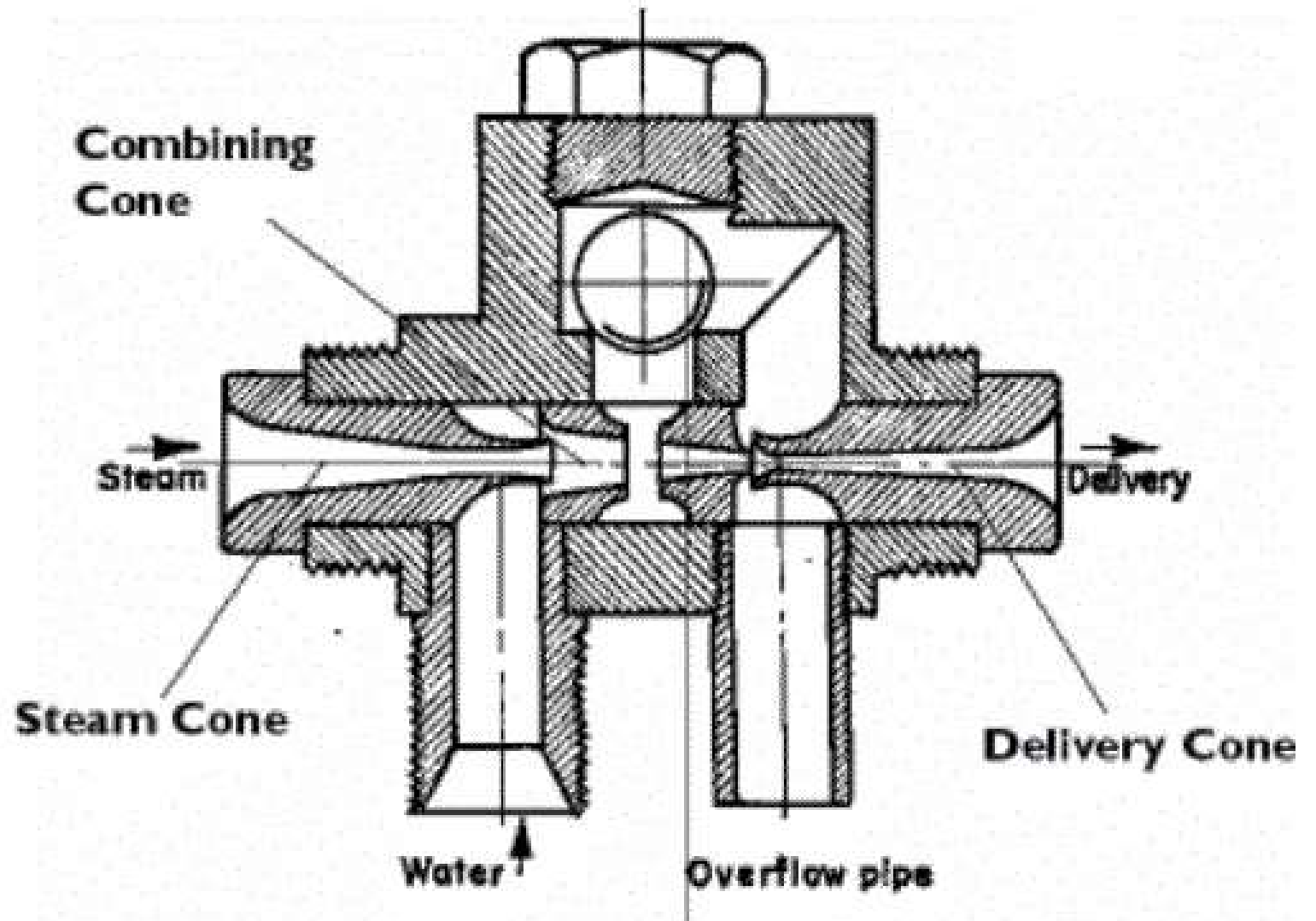
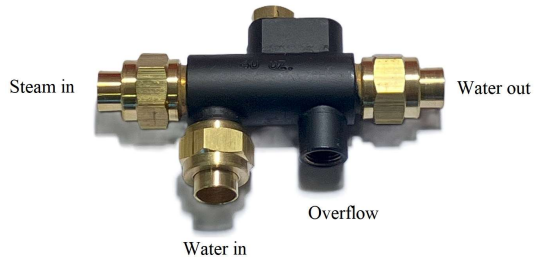

Other Stuff



Other Stuff

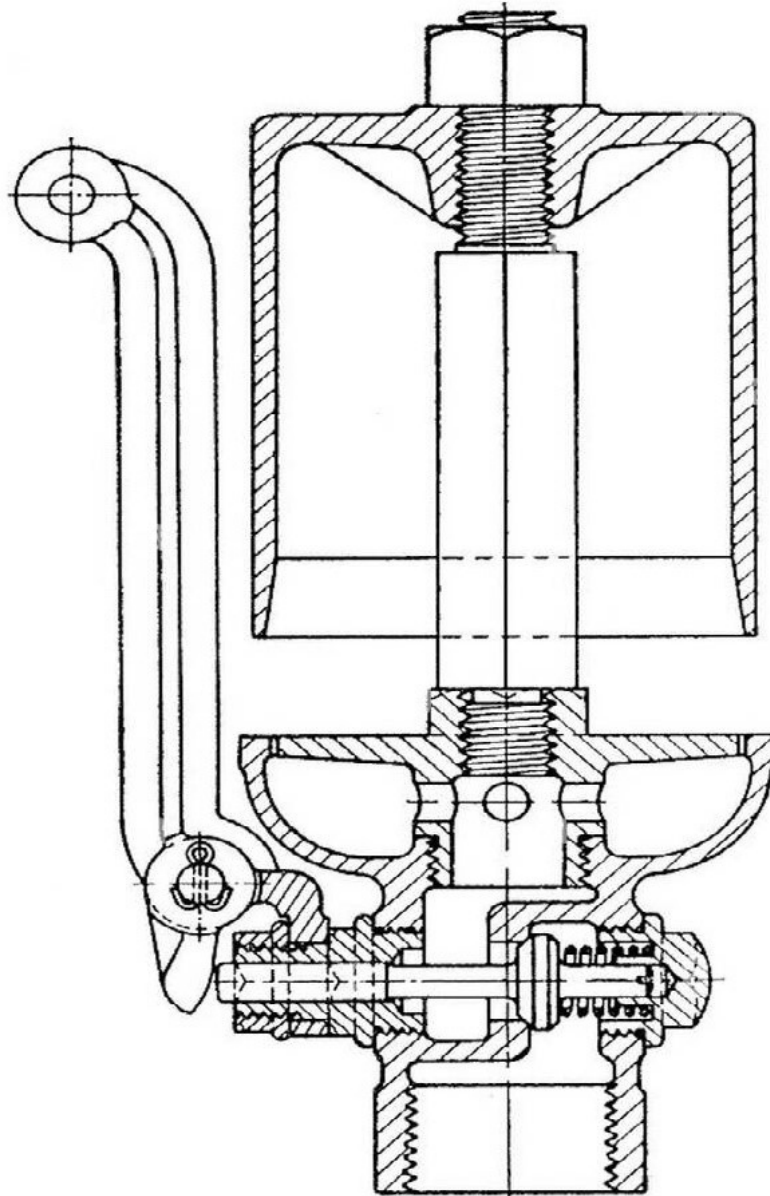

Other Stuff



Questions???